





# guilloché

Il guilloché è una tecnica decorativa di incisione realizzata con apposite macchine che, guidate manualmente, generano un preciso, intricato e ripetitivo pattern sul materiale di base. A differenza dell'incisione *tout court*, realizzata a mano, che si presta a un decoro più libero e naturalistico, quella realizzata con le macchine a guillocher è tipicamente meccanica e ripetitiva, consente però di ottenere un'infinità di pattern differenti al variare dei parametri di lavorazione combinandosi alla sensibilità tecnica, ma anche estetica, dell'operatore. L'origine esatta delle prime macchine non è nota con certezza. È possibile che abbiano paternità svizzera, forse per opera di un ingegnere francese di nome Guillot. I primi esempi di casse di orologio lavorate con questa tecnica portano inciso l'anno 1624. L'effettiva introduzione nel settore dell'orologeria risale al 1786, quando Abraham-Louis Breguet inizia a utilizzarla per decorare i quadranti e le casse dei suoi orologi. Questa tecnica sperimenta una straordinaria popolarità nel XIX secolo, grazie soprattutto all'opera di Peter Carl Fabergé.

Guilloche is a decorative engraving technique that uses special lathes. Guided manually, these machines draw a precise, intricate, repeated pattern on the metal surface. Different to freehand engraving, which is suited to more naturalistic and free decorations, guilloche engraving is typically mechanical and reiterative. It allows for infinite different patterns by varying the parameters of the process, which work in concert with the technician's technical sensibility and aesthetic judgement. The exact origin of the first guilloche machines is uncertain, but perhaps they were Swiss or invented by a French engineer named Guillot. The first examples of its use are found on watch cases engraved with the year 1624. The definitive introduction of guilloche in watchmaking dates back to 1786, when Abraham-Louis Breguet began using it to decorate the dials and cases of his watches. In the 19<sup>th</sup> century, the technique became highly popular, largely thanks to the work of Peter Carl Fabergé.

# Diana Barley Studio Olivari 2016

M1DBB



CR Cromo lucido/Bright chrome



NL SuperNichel lucido/  
SuperNickel bright



ZL SuperOro lucido/  
SuperGold bright

C1DB



K1DBB



**Barley “a chicco d’orzo”, allure brillante e sofisticata.**

La decorazione Barley riprende il classico motivo “a chicco d’orzo” della tradizione guilloché: la trama di fitte incisioni che si rincorrono conferisce alla maniglia un’allure brillante e sofisticata.

**Engraving similar to grains of barley with a shiny sophisticated allure.**

The Barley decoration is based on the classic grain motif of traditional guilloché engraving. The running, close-set pattern gives the handle shiny, sophisticated allure.

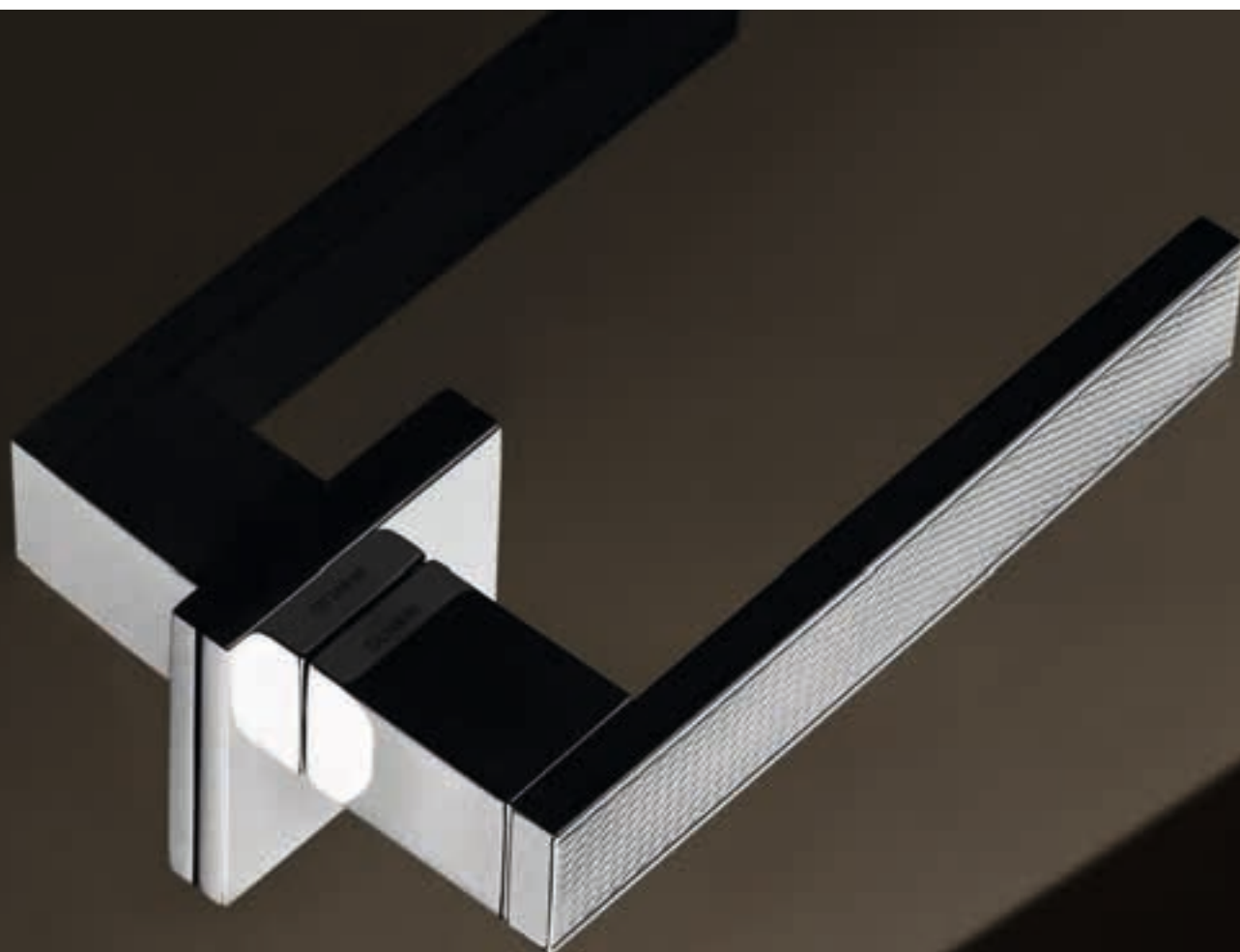

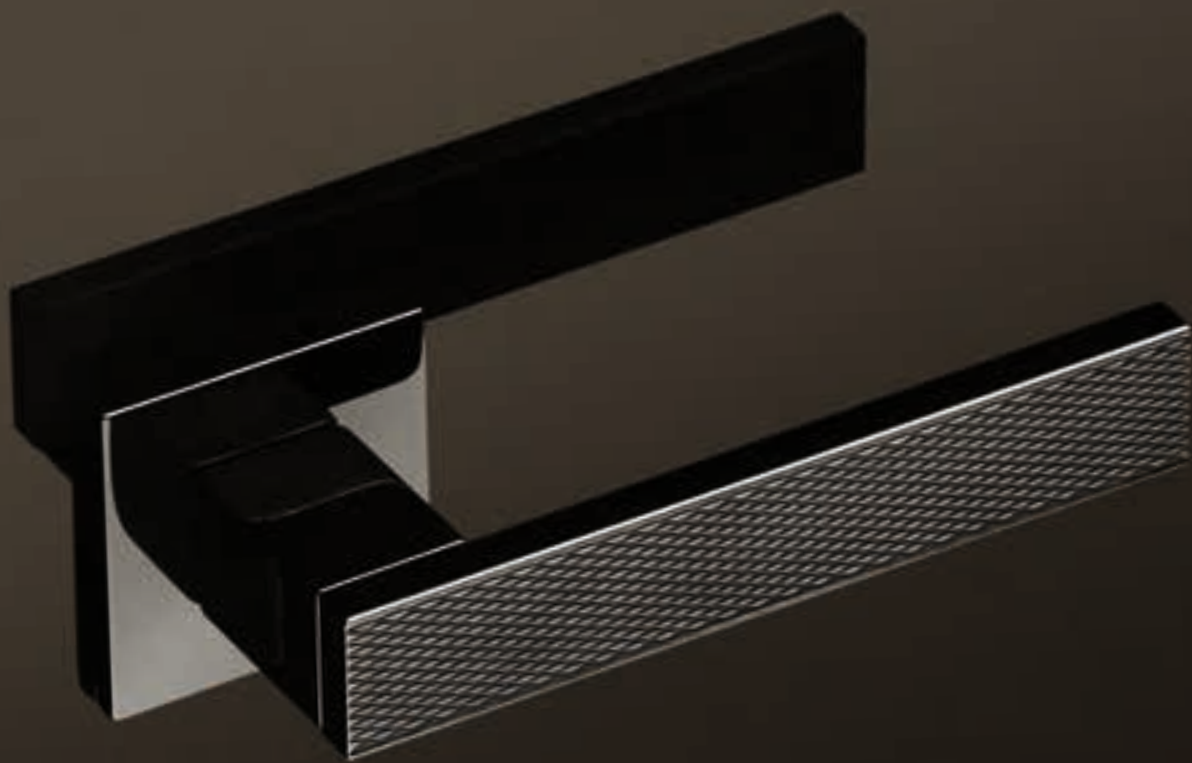





# Diana Damier Studio Olivari 2016

M1DDB



CR Cromo lucido/Bright chrome



NL SuperNichel lucido/  
SuperNickel bright



ZL SuperOro lucido/  
SuperGold bright

C1DD



K1DDB

**Damier "a scacchi", caratteri di un'eleganza sofisticata.**  
La decorazione Damier riprende il classico motivo "a scacchi" della tradizione guilloché: la trama di fitte incisioni alternate esprime i caratteri di un'eleganza sofisticata.

**Elegant chequers with a sophisticated air.**  
The Damier decoration takes up the classic chequerboard motif of traditional guilloché engraving with alternating squares of close-set patterns of sophisticated elegance.

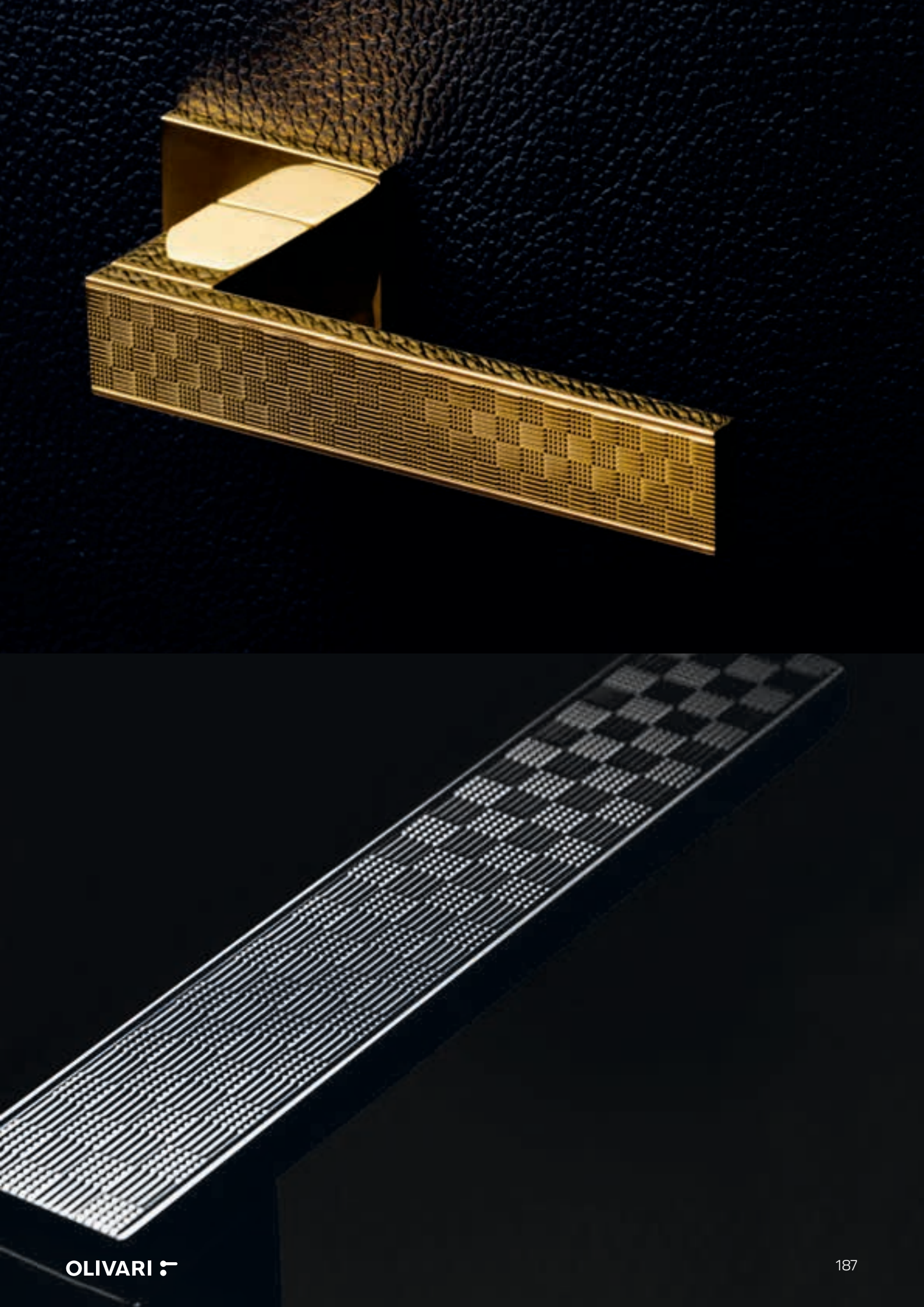



# Diana Chevron

Studio Olivari 2016

M1DCB



CR Cromo lucido/Bright chrome



NL SuperNichel lucido/  
SuperNickel bright



ZL SuperOro lucido/  
SuperGold bright

C1DC



K1DCB



**Chevron “a zig-zag” o “spina di pesce”, espressione di preziosità e raffinatezza.**

La decorazione Chevron riprende il classico motivo “a zig-zag”, o a “spina di pesce”, della tradizione guilloché, espressione di preziosità e raffinatezza.

**A herringbone motif expressing precious refinement.**  
The Chevron decoration takes up the classic herringbone motif of traditional guilloché engraving as an expression of preciousness and refinement.

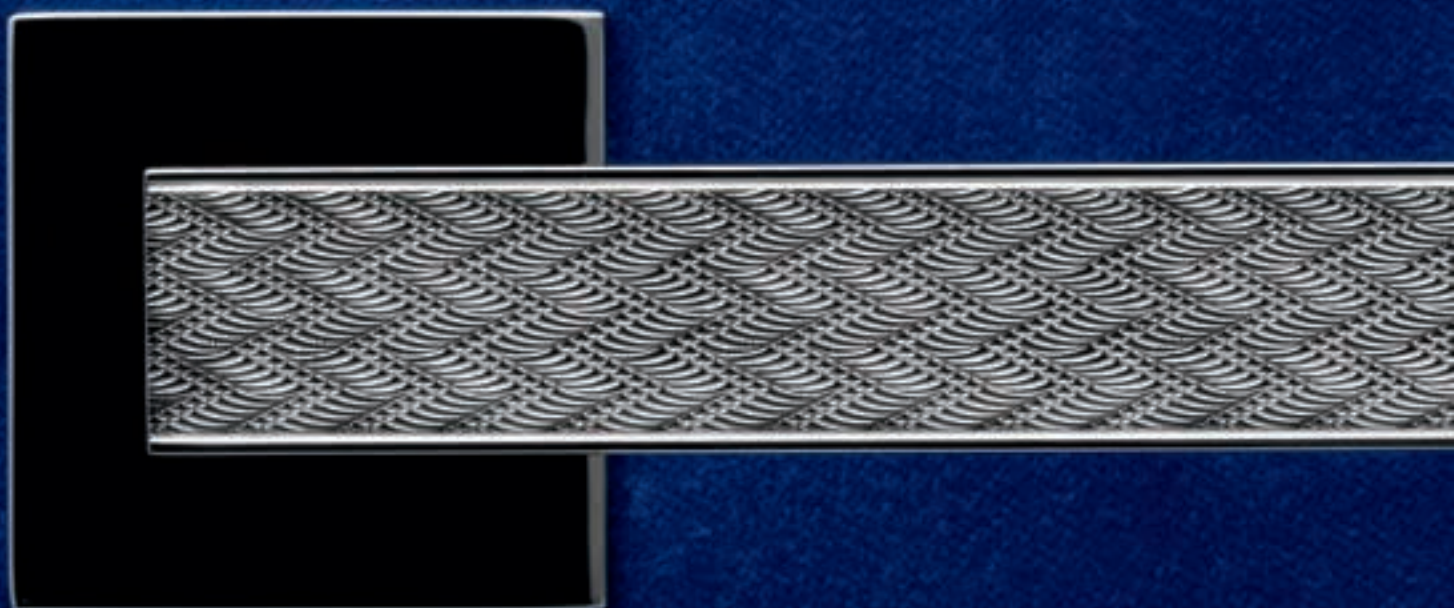



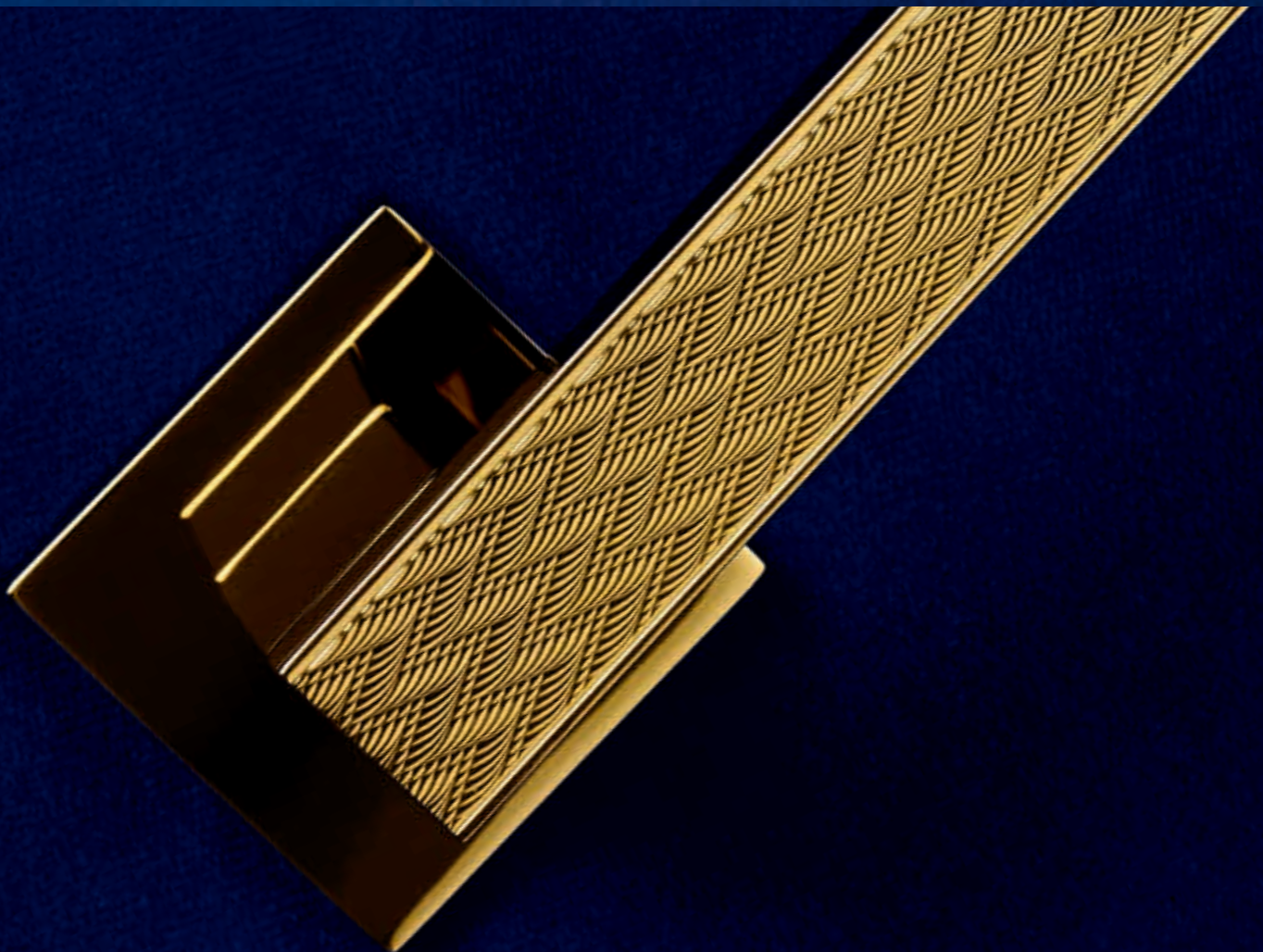

# Atena Ligne Studio Olivari 2016

M1ALB



CR Cromo lucido/Bright chrome



NL SuperNichel lucido/  
SuperNickel bright



ZL SuperOro lucido/  
SuperGold bright

C1AL



K1ALB



**Ligne “a righe”, eleganza essenziale e senza tempo.**

La decorazione Ligne sposa il classico motivo “a righe” della tradizione guilloché con la perfetta geometria cilindrica della maniglia per una soluzione di eleganza essenziale e senza tempo.

**An elegant linear pattern, timeless and understated.**

The Ligne decoration marries the classic lined motif of traditional guilloché engraving with the perfect cylindrical geometry of the handle, resulting in understated, timeless elegance.









# Atena Rank Studio Olivari 2016

M1ARB



CR Cromo lucido / Bright chrome



NL SuperNickel lucido /  
SuperNickel bright



ZL SuperOro lucido /  
SuperGold bright

C1AR



K1ARB



**Rank “a onda”, riflessi di forte carattere.**

La decorazione Rank riprende il classico motivo “a onda” della tradizione guilloché che ben si sposa con la purezza geometrica del cilindro creando riflessi di forte carattere.

**Wavy zigzags for characterful reflections.**

The Rank decoration takes up the classic wavy zigzag motif of traditional guilloché engraving, which lends itself perfectly to the geometrical pureness of the cylinder, creating characterful reflections.







# Atena Panier Studio Olivari 2016

M1APB



CR Cromo lucido/Bright chrome



NL SuperNichel lucido/  
SuperNickel bright



ZL SuperOro lucido/  
SuperGold bright

C1AP



K1APB



**Panier , intreccio di vimini delle ceste, eleganza e classicità.**

La decorazione Panier riprende il classico motivo della tradizione guilloché che allude all'intreccio di vimini delle ceste, esprimendo eleganza e classicità.

**A basket-weave pattern with classic elegance.**

The Panier decoration takes up the classic basket-weave motif of traditional guilloché engraving to express elegance and classicism.







placca

plate





# Placca orizzontale bassa Low horizontal plate

Adatta per tutte le maniglie  
Suitable for all catalogue handles

La placca orizzontale bassa è stata ideata come alternativa alla rosetta, per svolgere una duplice funzione.

Innanzitutto una funzione estetica:

essendo una sorta di sfondo, di proiezione della maniglia, rende l'insieme un tutt'uno integrato, con forte segnalazione e connotazione.

In secondo luogo una funzione tecnica:

la sua estensione dietro la maniglia impedisce di toccare la porta e quindi evita il rischio di urtarla e rovinarla.

Per consentire di utilizzare la placca orizzontale con tutte le maniglie del catalogo, sono state realizzate due versioni: una rettangolare e una ovale. Entrambe sono dotate di molla di ritorno molto robusta e di posizione di arresto orizzontale, al fine di riportare sempre in corretta posizione la maniglia dopo il suo utilizzo. Testate secondo la prova di resistenza (norma DIN EN 1906), hanno superato i 200.000 cicli, risultando appartenere alla classe 4, cioè adatte agli utilizzi gravosi. Di fatto poi la prova è stata prolungata fino a 1.000.000 di cicli, che sono stati agevolmente superati.

The low horizontal plate was designed as an alternative to the rosette, to perform a dual function.

First of all, an aesthetic function:

being a sort of backdrop, an extension of the door handle, it creates the effect of one whole integrated piece, with strong expression and substance.

Secondly, a technical function:

its presence prevents the door handle from touching the door and therefore avoids the risk of hitting and damaging it.

To allow the use of the horizontal plate with all the door handles in the catalogue, two versions have been made: a rectangular and an oval version. Both are equipped with a very strong return spring and a horizontal stop position, in order to always return the door handle to its correct position after use. Tested according to the resistance test (DIN EN 1906), they exceeded 200,000 cycles, resulting in grade 4 classification, that is suitable for heavy use. In fact, the test was extended up to 1,000,000 cycles, which was easily exceeded.

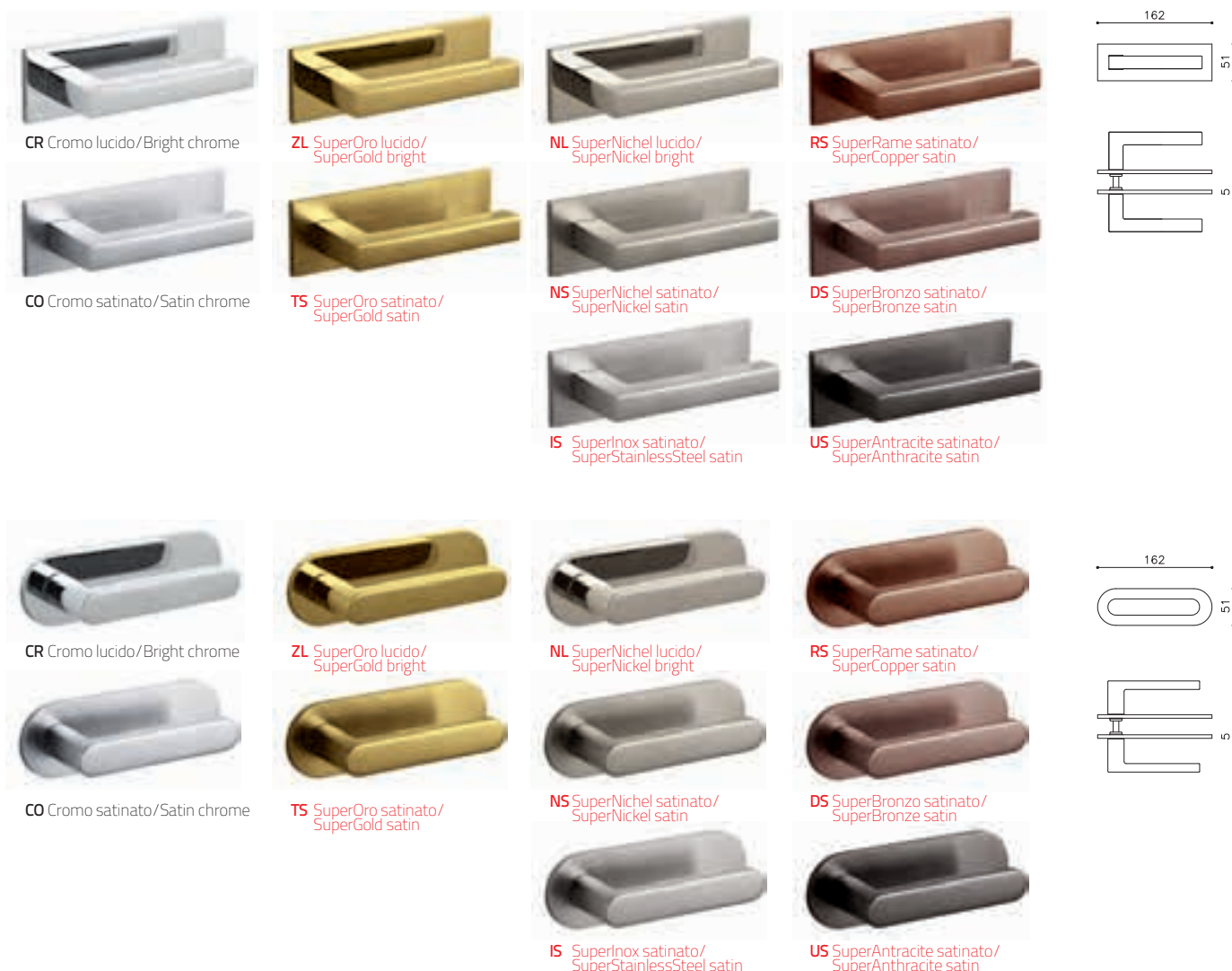





pomoli zancati  
pomoli centrali

offset door knobs  
central door knobs



Pomoli zancati

## Planet Q Studio Olivari



ottone/brass

CR Cromo lucido/Bright chrome  
CO Cromo satinato/Satin chrome  
IS SuperInox satinato/  
SuperStainlessSteel satin

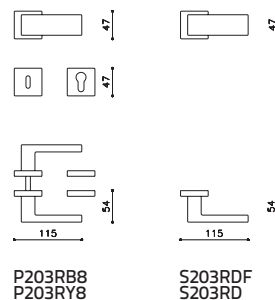

P203RB8  
P203RY8

S203RDF  
S203RD

## Planet Studio Olivari



ottone/brass

CR Cromo lucido/Bright chrome  
CO Cromo satinato/Satin chrome  
NS SuperNichel satinato/  
SuperNickel satin  
IS SuperInox satinato/  
SuperStainlessSteel satin

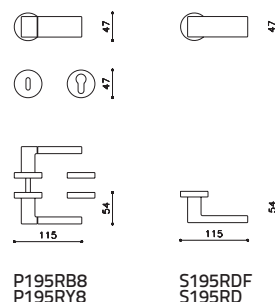

P195RB8  
P195RY8

S195RDF  
S195RD

## Blindo Studio Olivari



ottone/brass

CR Cromo lucido/Bright chrome  
CO Cromo satinato/Satin chrome  
ZL SuperOro lucido/SuperGold bright  
TS SuperOro satinato/SuperGold satin  
NL SuperNichel lucido/  
SuperNickel bright  
NS SuperNichel satinato/  
SuperNickel satin  
IS SuperInox satinato/  
SuperStainlessSteel satin  
RS SuperRame satinato/  
SuperCopper satin  
DS SuperBronzo satinato/  
SuperBronze satin  
US SuperAntracite satinato/  
SuperAnthracite satin

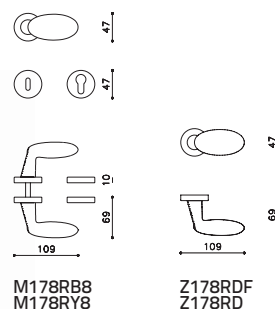

M178RB8  
M178RY8

Z178RDF  
Z178RD

## Uovo Studio Olivari



ottone/brass

CR Cromo lucido/Bright chrome  
CO Cromo satinato/Satin chrome  
NP Nero opaco/Mat black  
ZL SuperOro lucido/SuperGold bright  
TS SuperOro satinato/SuperGold satin  
DS SuperBronzo satinato/  
SuperBronze satin

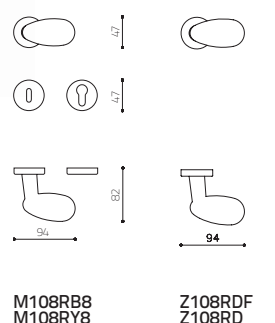

M108RB8  
M108RY8

Z108RDF  
Z108RD

## Bond Andrea Branzi



ottone/brass

CO Cromo satinato/Satin chrome  
ZL SuperOro lucido/SuperGold bright

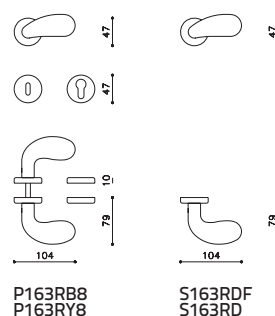

P163RB8  
P163RY8

S163RDF  
S163RD

# Diana Studio Olivari



**ottone/brass**

- CR Cromo lucido/Bright chrome
- CO Cromo satinato/Satin chrome
- ZL SuperOro lucido/SuperGold bright
- NL SuperNichel lucido/SuperNickel bright
- IS SuperInox satinato/SuperStainlessSteel satin
- RS SuperRame satinato/SuperCopper satin
- DS SuperBronzo satinato/SuperBronze satin
- US SuperAntracite satinato/SuperAnthracite satin

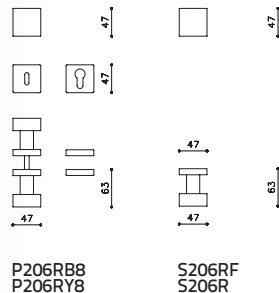

P206RB8  
P206RY8

S206RF  
S206R



**ottone/brass**

- CR Cromo lucido/Bright chrome
- CO Cromo satinato/Satin chrome
- ZL SuperOro lucido/SuperGold bright
- NL SuperNichel lucido/SuperNickel bright
- IS SuperInox satinato/SuperStainlessSteel satin
- RS SuperRame satinato/SuperCopper satin
- DS SuperBronzo satinato/SuperBronze satin
- US SuperAntracite satinato/SuperAnthracite satin

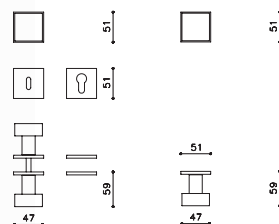

P206RB8B  
P206RY8B

S206RFB  
S206RB

# Link Piero Lissoni



**ottone/brass**

- CR Cromo lucido/Bright chrome
- CO Cromo satinato/Satin chrome
- ZL SuperOro lucido/SuperGold bright
- NL SuperNichel lucido/SuperNickel bright
- NS SuperNichel satinato/SuperNickel satin
- IS SuperInox satinato/SuperStainlessSteel satin
- RS SuperRame satinato/SuperCopper satin
- DS SuperBronzo satinato/SuperBronze satin
- US SuperAntracite satinato/SuperAnthracite satin

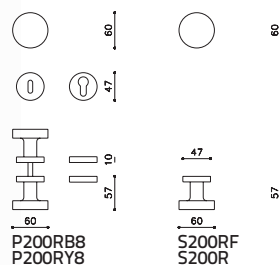

P200RB8  
P200RY8

S200RF  
S200R



**ottone/brass**

- CR Cromo lucido/Bright chrome
- CO Cromo satinato/Satin chrome
- ZL SuperOro lucido/SuperGold bright
- NL SuperNichel lucido/SuperNickel bright
- NS SuperNichel satinato/SuperNickel satin
- IS SuperInox satinato/SuperStainlessSteel satin
- RS SuperRame satinato/SuperCopper satin
- DS SuperBronzo satinato/SuperBronze satin
- US SuperAntracite satinato/SuperAnthracite satin

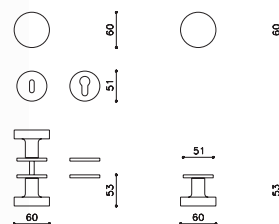

P200RB8B  
P200RY8B

S200RFB  
S200RB

# Oscar Studio Olivari



**ottone/brass**

- CR Cromo lucido/Bright chrome
- CO Cromo satinato/Satin chrome
- NL SuperNichel lucido/  
SuperNickel bright
- RS SuperRame satinato/  
SuperCopper satin
- DS SuperBronzo satinato/  
SuperBronze satin

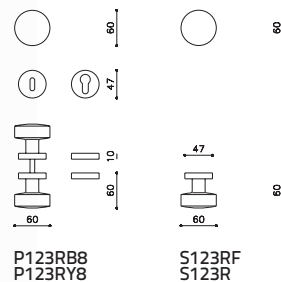

# Roger Studio Olivari



**ottone/brass**

- CR Cromo lucido/Bright chrome
- CO Cromo satinato/Satin chrome
- TS SuperOro satinato/SuperGold satin
- NL SuperNichel lucido/  
SuperNickel bright
- RS SuperRame satinato/  
SuperCopper satin
- DS SuperBronzo satinato/  
SuperBronze satin

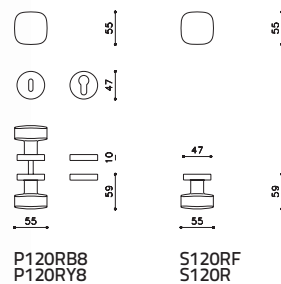



## Edison ø 60 Mazza, Gramigna



**ottone/brass**

- CR Cromo lucido/Bright chrome
- CO Cromo satinato/Satin chrome
- ZL SuperOro lucido/SuperGold bright
- TS SuperOro satinato/SuperGold satin
- NL SuperNichel lucido/SuperNickel bright
- IS SuperInox satinato/SuperStainlessSteel satin
- RS SuperRame satinato/SuperCopper satin
- DS SuperBronzo satinato/SuperBronze satin
- US SuperAntracite satinato/SuperAnthracite satin

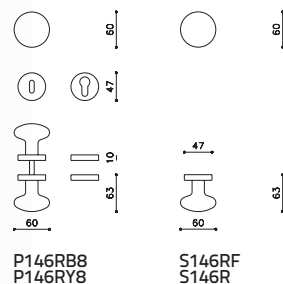

P146RB8  
P146RY8

S146RF  
S146R

## Edison ø 70 Mazza, Gramigna



**ottone/brass**

- CR Cromo lucido/Bright chrome
- CO Cromo satinato/Satin chrome
- ZL SuperOro lucido/SuperGold bright
- TS SuperOro satinato/SuperGold satin
- NL SuperNichel lucido/SuperNickel bright
- IS SuperInox satinato/SuperStainlessSteel satin
- RS SuperRame satinato/SuperCopper satin
- DS SuperBronzo satinato/SuperBronze satin
- US SuperAntracite satinato/SuperAnthracite satin

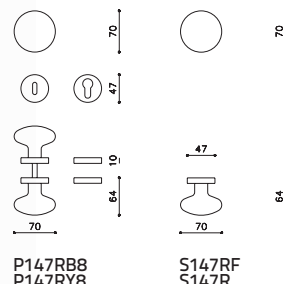

P147RB8  
P147RY8

S147RF  
S147R

## Edison ø 80 Mazza, Gramigna



**ottone/brass**

- CR Cromo lucido/Bright chrome
- CO Cromo satinato/Satin chrome

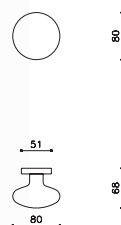

S148RF



# chiavistelli

latches



# Cubo Studio Olivari



**ottone/brass**

- CR Cromo lucido/Bright chrome
- CO Cromo satinato/Satin chrome
- ZL SuperOro lucido/SuperGold bright
- NL SuperNichel lucido/SuperNickel bright
- NS SuperNichel satinato/SuperNickel satin
- IS SuperInox satinato/SuperStainlessSteel satin
- RS SuperRame satinato/SuperCopper satin
- DS SuperBronzo satinato/SuperBronze satin
- US SuperAntracite satinato/SuperAnthracite satin

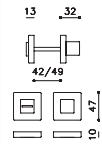

H136V6

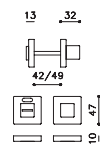

H136VF6

# Space Q Studio Olivari



**ottone/brass**

- CR Cromo lucido/Bright chrome
- CO Cromo satinato/Satin chrome
- ZL SuperOro lucido/SuperGold bright
- NL SuperNichel lucido/SuperNickel bright
- NS SuperNichel satinato/SuperNickel satin
- IS SuperInox satinato/SuperStainlessSteel satin
- RS SuperRame satinato/SuperCopper satin
- DS SuperBronzo satinato/SuperBronze satin
- US SuperAntracite satinato/SuperAnthracite satin

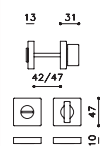

H202V6

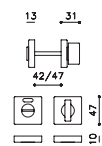

H202VF6

Verona Q Studio Olivari



ottone/brass

- CR Cromo lucido/Bright chrome
- CO Cromo satinato/Satin chrome
- ZL SuperOro lucido/SuperGold bright
- NL SuperNichel lucido/SuperNickel bright
- NS SuperNichel satinato/SuperNickel satin
- IS SuperInox satinato/SuperStainlessSteel satin
- RS SuperRame satinato/SuperCopper satin
- DS SuperBronzo satinato/SuperBronze satin
- US SuperAntracite satinato/SuperAnthracite satin

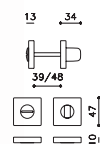

H117V6

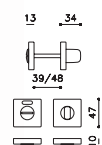

H118V6

# Link Piero Lissoni



**ottone/brass**

- CR Cromo lucido/Bright chrome
- CO Cromo satinato/Satin chrome
- ZL SuperOro lucido/SuperGold bright
- TS SuperOro satinato/SuperGold satin
- NL SuperNichel lucido/SuperNickel bright
- NS SuperNichel satinato/SuperNickel satin
- IS SuperInox satinato/  
SuperStainlessSteel satin
- RS SuperRame satinato/  
SuperCopper satin
- DS SuperBronzo satinato/  
SuperBronze satin
- US SuperAntracite satinato/  
SuperAnthracite satin

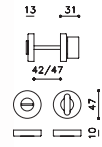

H200V6

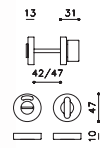

H200VF6

# Space Studio Olivari



**ottone/brass**

- CR Cromo lucido/Bright chrome
- CO Cromo satinato/Satin chrome
- ZL SuperOro lucido/SuperGold bright
- NL SuperNichel lucido/SuperNickel bright
- NS SuperNichel satinato/SuperNickel satin
- IS SuperInox satinato/  
SuperStainlessSteel satin
- RS SuperRame satinato/  
SuperCopper satin
- DS SuperBronzo satinato/  
SuperBronze satin
- US SuperAntracite satinato/  
SuperAnthracite satin

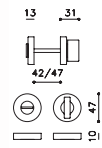

H193V6

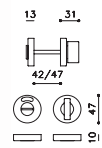

H193VF6

Verona V Studio Olivari



ottone/brass

- CR Cromo lucido/Bright chrome
- CO Cromo satinato/Satin chrome
- NP Nero opaco/Mat black
- ZL SuperOro lucido/SuperGold bright
- TS SuperOro satinato/SuperGold satin
- NL SuperNichel lucido/SuperNickel bright
- NS SuperNichel satinato/SuperNickel satin
- IS SuperInox satinato/SuperStainlessSteel satin
- RS SuperRame satinato/SuperCopper satin
- DS SuperBronzo satinato/SuperBronze satin
- US SuperAntracite satinato/SuperAnthracite satin

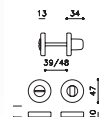

H106V6

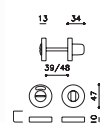

H109V6

Verona R Studio Olivari



ottone/brass

- CR Cromo lucido/Bright chrome
- CO Cromo satinato/Satin chrome
- ZL SuperOro lucido/SuperGold bright
- TS SuperOro satinato/SuperGold satin
- NL SuperNichel lucido/SuperNickel bright
- NS SuperNichel satinato/SuperNickel satin
- IS SuperInox satinato/SuperStainlessSteel satin
- RS SuperRame satinato/SuperCopper satin
- DS SuperBronzo satinato/SuperBronze satin

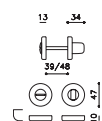

H107R6

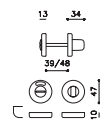

H108R6



# Alexandra F.A. Porsche



ottone/brass

CR Cromo lucido/Bright chrome  
CO Cromo satinato/Satin chrome  
IS SuperInox satinato/  
SuperStainlesssteel satin

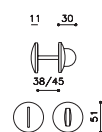

H150/6

# Icaro Paolo Portoghesi



ottone/brass

ZL SuperOro lucido/SuperGold bright

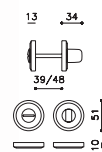

H168R6

Cubo Studio Olivari



ottone/brass

- CR Cromo lucido/Bright chrome
- CO Cromo satinato/Satin chrome
- ZL SuperOro lucido/SuperGold bright
- NL SuperNichel lucido/SuperNickel bright
- NS SuperNichel satinato/SuperNickel satin
- IS SuperInox satinato/SuperStainlessSteel satin
- RS SuperRame satinato/SuperCopper satin
- DS SuperBronzo satinato/SuperBronze satin
- US SuperAntracite satinato/SuperAnthracite satin

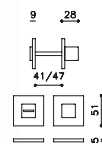

H136V6B

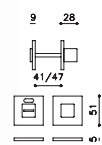

H136VF6B

Link Q Piero Lissoni



ottone/brass

- CR Cromo lucido/Bright chrome
- CO Cromo satinato/Satin chrome
- ZL SuperOro lucido/SuperGold bright
- TS SuperOro satinato/SuperGold satin
- NL SuperNichel lucido/SuperNickel bright
- NS SuperNichel satinato/SuperNickel satin
- IS SuperInox satinato/SuperStainlessSteel satin
- RS SuperRame satinato/SuperCopper satin
- DS SuperBronzo satinato/SuperBronze satin
- US SuperAntracite satinato/SuperAnthracite satin

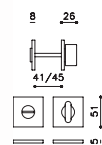

H209V6B

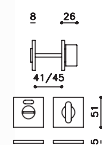

H209VF6B

# Space Q Studio Olivari



**ottone/brass**

- CR Cromo lucido/Bright chrome
- CO Cromo satinato/Satin chrome
- ZL SuperOro lucido/SuperGold bright
- TS SuperOro satinato/SuperGold satin
- NL SuperNichel lucido/SuperNickel bright
- NS SuperNichel satinato/SuperNickel satin
- IS SuperInox satinato/  
SuperStainlessSteel satin
- RS SuperRame satinato/  
SuperCopper satin
- DS SuperBronzo satinato/  
SuperBronze satin
- US SuperAntracite satinato/  
SuperAnthracite satin

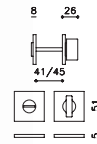

H202V6B

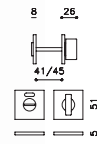

H202VF6B

# Verona Q Studio Olivari



**ottone/brass**

- CR Cromo lucido/Bright chrome
- CO Cromo satinato/Satin chrome
- ZL SuperOro lucido/SuperGold bright
- TS SuperOro satinato/SuperGold satin
- NL SuperNichel lucido/SuperNickel bright
- NS SuperNichel satinato/SuperNickel satin
- IS SuperInox satinato/  
SuperStainlessSteel satin
- RS SuperRame satinato/  
SuperCopper satin
- DS SuperBronzo satinato/  
SuperBronze satin
- US SuperAntracite satinato/  
SuperAnthracite satin

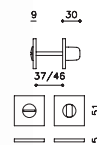

H117V6B

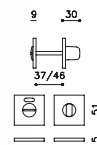

H117VF6B

Link Piero Lissoni



ottone/brass

- CR Cromo lucido/Bright chrome
- CO Cromo satinato/Satin chrome
- ZL SuperOro lucido/SuperGold bright
- TS SuperOro satinato/SuperGold satin
- NL SuperNichel lucido/SuperNickel bright
- NS SuperNichel satinato/SuperNickel satin
- IS SuperInox satinato/  
SuperStainlessSteel satin
- RS SuperRame satinato/  
SuperCopper satin
- DS SuperBronzo satinato/  
SuperBronze satin
- US SuperAntracite satinato/  
SuperAnthracite satin

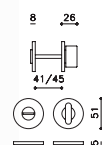

H200V6B

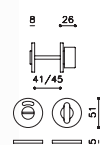

H200VF6B

Verona V Studio Oliavri



ottone/brass

- CR Cromo lucido/Bright chrome
- CO Cromo satinato/Satin chrome
- ZL SuperOro lucido/SuperGold bright
- TS SuperOro satinato/SuperGold satin
- NL SuperNichel lucido/SuperNickel bright
- NS SuperNichel satinato/SuperNickel satin
- IS SuperInox satinato/  
SuperStainlessSteel satin
- RS SuperRame satinato/  
SuperCopper satin
- DS SuperBronzo satinato/  
SuperBronze satin
- US SuperAntracite satinato/  
SuperAnthracite satin

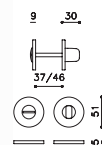

H106V6B

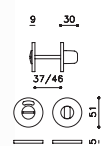

H106VF6B



## Cubo S Studio Olivari



**ottone/brass**

- CR Cromo lucido/Bright chrome
- CO Cromo satinato/Satin chrome
- ZL SuperOro lucido/SuperGold bright
- NL SuperNichel lucido/SuperNickel bright
- NS SuperNichel satinato/SuperNickel satin
- IS SuperInox satinato/SuperStainlessSteel satin
- RS SuperRame satinato/SuperCopper satin
- DS SuperBronzo satinato/SuperBronze satin
- US SuperAntracite satinato/SuperAnthracite satin

14 23



H135B6

## Link S Piero Lissoni



**ottone/brass**

- CR Cromo lucido/Bright chrome
- CO Cromo satinato/Satin chrome
- ZL SuperOro lucido/SuperGold bright
- TS SuperOro satinato/SuperGold satin
- NL SuperNichel lucido/SuperNickel bright
- NS SuperNichel satinato/SuperNickel satin
- IS SuperInox satinato/SuperStainlessSteel satin
- RS SuperRame satinato/SuperCopper satin
- DS SuperBronzo satinato/SuperBronze satin
- US SuperAntracite satinato/SuperAnthracite satin

13 21



H199B6

## Space S Studio Olivari



**ottone/brass**

- CR Cromo lucido/Bright chrome
- CO Cromo satinato/Satin chrome
- ZL SuperOro lucido/SuperGold bright
- TS SuperOro satinato/SuperGold satin
- NL SuperNichel lucido/SuperNickel bright
- NS SuperNichel satinato/SuperNickel satin
- IS SuperInox satinato/SuperStainlessSteel satin
- RS SuperRame satinato/SuperCopper satin
- DS SuperBronzo satinato/SuperBronze satin
- US SuperAntracite satinato/SuperAnthracite satin

13 21



H192B6

## Verona S Studio Olivari



**ottone/brass**

- CR Cromo lucido/Bright chrome
- CO Cromo satinato/Satin chrome
- NP Nero opaco/Mat black
- ZL SuperOro lucido/SuperGold bright
- TS SuperOro satinato/SuperGold satin
- NL SuperNichel lucido/SuperNickel bright
- NS SuperNichel satinato/SuperNickel satin
- IS SuperInox satinato/SuperStainlessSteel satin
- RS SuperRame satinato/SuperCopper satin
- DS SuperBronzo satinato/SuperBronze satin
- US SuperAntracite satinato/SuperAnthracite satin

14 25



H105B6

# Giotto Q Studio Olivari



**ottone/brass**

- CR Cromo lucido / Bright chrome
- CO Cromo satinato / Satin chrome
- CA Cromo lucido-satinato / Chrome bright-satin
- ZL SuperOro lucido / SuperGold bright
- TS SuperOro satinato / SuperGold satin
- NL SuperNichel lucido / SuperNickel bright
- NS SuperNichel satinato / SuperNickel satin
- IS SuperInox satinato / SuperStainlessSteel satin
- RS SuperRame satinato / SuperCopper satin
- DS SuperBronzo satinato / SuperBronze satin
- US SuperAntracite satinato / SuperAnthracite satin

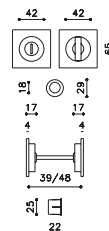

D127



**ottone/brass**

- CR Cromo lucido / Bright chrome
- CO Cromo satinato / Satin chrome
- CA Cromo lucido-satinato / Chrome bright-satin
- ZL SuperOro lucido / SuperGold bright
- TS SuperOro satinato / SuperGold satin
- NL SuperNichel lucido / SuperNickel bright
- NS SuperNichel satinato / SuperNickel satin
- IS SuperInox satinato / SuperStainlessSteel satin
- RS SuperRame satinato / SuperCopper satin
- DS SuperBronzo satinato / SuperBronze satin
- US SuperAntracite satinato / SuperAnthracite satin

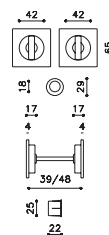

D128



**ottone/brass**

- CR Cromo lucido / Bright chrome
- CO Cromo satinato / Satin chrome
- CA Cromo lucido-satinato / Chrome bright-satin
- ZL SuperOro lucido / SuperGold bright
- TS SuperOro satinato / SuperGold satin
- NL SuperNichel lucido / SuperNickel bright
- NS SuperNichel satinato / SuperNickel satin
- IS SuperInox satinato / SuperStainlessSteel satin
- RS SuperRame satinato / SuperCopper satin
- DS SuperBronzo satinato / SuperBronze satin
- US SuperAntracite satinato / SuperAnthracite satin

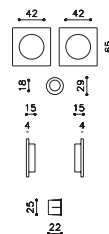

D129



**ottone/brass**

- CR Cromo lucido / Bright chrome
- CO Cromo satinato / Satin chrome
- CA Cromo lucido-satinato / Chrome bright-satin
- ZL SuperOro lucido / SuperGold bright
- TS SuperOro satinato / SuperGold satin
- NL SuperNichel lucido / SuperNickel bright
- NS SuperNichel satinato / SuperNickel satin
- IS SuperInox satinato / SuperStainlessSteel satin
- RS SuperRame satinato / SuperCopper satin
- DS SuperBronzo satinato / SuperBronze satin
- US SuperAntracite satinato / SuperAnthracite satin

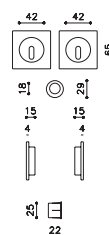

D130

# Giotto Nicola Novelletto



**ottone/brass**

- CR Cromo lucido /Bright chrome
- CO Cromo satinato/Satin chrome
- CA Cromo lucido-satinato/  
Chrome bright-satin
- ZL SuperOro lucido/SuperGold bright
- NS SuperNichel satinato/  
SuperNickel satin
- IS SuperInox satinato/  
SuperStainlessSteel satin

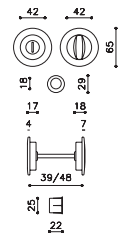

D122



**ottone/brass**

- CR Cromo lucido /Bright chrome
- CO Cromo satinato/Satin chrome
- CA Cromo lucido-satinato/  
Chrome bright-satin
- ZL SuperOro lucido/SuperGold bright
- NS SuperNichel satinato/  
SuperNickel satin
- IS SuperInox satinato/  
SuperStainlessSteel satin

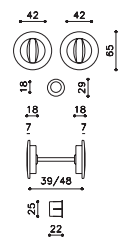

D123



**ottone/brass**

- CR Cromo lucido /Bright chrome
- CO Cromo satinato/Satin chrome
- CA Cromo lucido-satinato/  
Chrome bright-satin
- ZL SuperOro lucido/SuperGold bright
- NS SuperNichel satinato/  
SuperNickel satin
- IS SuperInox satinato/  
SuperStainlessSteel satin

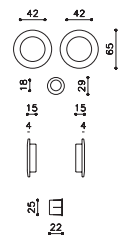

D124



**ottone/brass**

- CR Cromo lucido /Bright chrome
- CO Cromo satinato/Satin chrome
- CA Cromo lucido-satinato/  
Chrome bright-satin
- ZL SuperOro lucido/SuperGold bright
- NS SuperNichel satinato/  
SuperNickel satin
- IS SuperInox satinato/  
SuperStainlessSteel satin

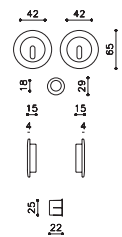

D125

Dante Studio Olivari



ottone/brass

- CR Cromo lucido / Bright chrome
- CO Cromo satinato / Satin chrome
- CA Cromo lucido-satinato / Chrome bright-satin
- ZL SuperOro lucido / SuperGold bright
- TS SuperOro satinato / SuperGold satin
- NL SuperNichel lucido / SuperNickel bright
- NS SuperNichel satinato / SuperNickel satin
- IS SuperInox satinato / SuperStainlessSteel satin
- RS SuperRame satinato / SuperCopper satin
- DS SuperBronzo satinato / SuperBronze satin
- US SuperAntracite satinato / SuperAnthracite satin

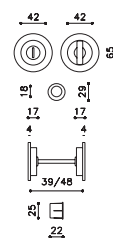

D132



ottone/brass

- CR Cromo lucido / Bright chrome
- CO Cromo satinato / Satin chrome
- CA Cromo lucido-satinato / Chrome bright-satin
- ZL SuperOro lucido / SuperGold bright
- TS SuperOro satinato / SuperGold satin
- NL SuperNichel lucido / SuperNickel bright
- NS SuperNichel satinato / SuperNickel satin
- IS SuperInox satinato / SuperStainlessSteel satin
- RS SuperRame satinato / SuperCopper satin
- DS SuperBronzo satinato / SuperBronze satin
- US SuperAntracite satinato / SuperAnthracite satin

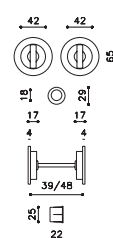

D133



ottone/brass

- CR Cromo lucido / Bright chrome
- CO Cromo satinato / Satin chrome
- CA Cromo lucido-satinato / Chrome bright-satin
- ZL SuperOro lucido / SuperGold bright
- TS SuperOro satinato / SuperGold satin
- NL SuperNichel lucido / SuperNickel bright
- NS SuperNichel satinato / SuperNickel satin
- IS SuperInox satinato / SuperStainlessSteel satin
- RS SuperRame satinato / SuperCopper satin
- DS SuperBronzo satinato / SuperBronze satin
- US SuperAntracite satinato / SuperAnthracite satin

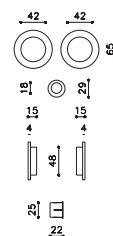

D134



ottone/brass

- CR Cromo lucido / Bright chrome
- CO Cromo satinato / Satin chrome
- CA Cromo lucido-satinato / Chrome bright-satin
- ZL SuperOro lucido / SuperGold bright
- TS SuperOro satinato / SuperGold satin
- NL SuperNichel lucido / SuperNickel bright
- NS SuperNichel satinato / SuperNickel satin
- IS SuperInox satinato / SuperStainlessSteel satin
- RS SuperRame satinato / SuperCopper satin
- DS SuperBronzo satinato / SuperBronze satin
- US SuperAntracite satinato / SuperAnthracite satin

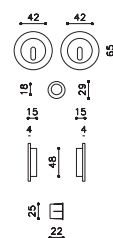

D135



## Siro Studio Olivari



**ottone/brass**

- CR Cromo lucido /Bright chrome
- CO Cromo satinato/Satin chrome
- ZL SuperOro lucido/SuperGold bright
- TS SuperOro satinato/SuperGold satin
- NL SuperNichel lucido/SuperNickel bright
- NS SuperNichel satinato/SuperNickel satin
- IS SuperInox satinato/SuperStainlessSteel satin
- RS SuperRame satinato/SuperCopper satin
- DS SuperBronzo satinato/SuperBronze satin
- US SuperAntracite satinato/SuperAnthracite satin

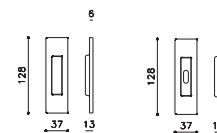

D111

D111F

## Vico Studio Olivari



**ottone/brass**

- CR Cromo lucido /Bright chrome
- CO Cromo satinato/Satin chrome
- ZL SuperOro lucido/SuperGold bright
- TS SuperOro satinato/SuperGold satin
- NL SuperNichel lucido/SuperNickel bright
- NS SuperNichel satinato/SuperNickel satin
- IS SuperInox satinato/SuperStainlessSteel satin
- RS SuperRame satinato/SuperCopper satin
- DS SuperBronzo satinato/SuperBronze satin
- US SuperAntracite satinato/SuperAnthracite satin

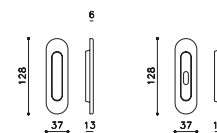

D109

D109F

## Time Studio Olivari



**ottone/brass**

- CR Cromo lucido/Bright chrome
- CO Cromo satinato/Satin chrome
- ZL SuperOro lucido/SuperGold bright
- NS SuperNichel satinato/SuperNickel satin
- IS SuperInox satinato/SuperStainlessSteel satin
- US SuperAntracite satinato/SuperAnthracite satin

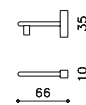

F192

## Polo Rodolfo Bonetto



**ottone/brass**

- CR Cromo lucido/Bright chrome
- CO Cromo satinato/Satin chrome
- ZL SuperOro lucido/SuperGold bright
- TS SuperOro satinato/SuperGold satin
- NS SuperNichel satinato/SuperNickel satin
- IS SuperInox satinato/SuperStainlessSteel satin
- US SuperAntracite satinato/SuperAnthracite satin



F152

## Delphina Massimo Iosa Ghini



**ottone/brass**

- CO Cromo satinato/Satin chrome
- ZL SuperOro lucido/SuperGold bright
- IS SuperInox satinato/SuperStainlessSteel satin
- US SuperAntracite satinato/SuperAnthracite satin



F158

# maniglioni

pull handles

# Planet Q Studio Olivari



**ottone/brass**

**CR** Cromo lucido/Bright chrome

**CO** Cromo satinato/Satin chrome

**CA** Cromo lucido-satinato/  
Chrome bright-satin

**ZL** SuperOro lucido/SuperGold bright

**NL** SuperNichel lucido/  
SuperNickel bright

**NS** SuperNichel satinato/  
SuperNickel satin

**IS** SuperInox satinato/  
SuperStainlessSteel satin

**RS** SuperRame satinato/  
SuperCopper satin

**DS** SuperBronzo satinato/  
SuperBronze satin

**US** SuperAntracite satinato/  
SuperAnthracite satin

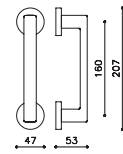

L195R

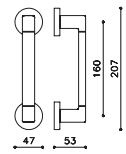

L195R

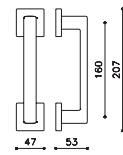

L203R

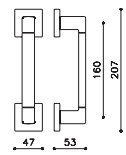

L203R

Planet Studio Olivari



**ottone/brass**

- CR Cromo lucido/Bright chrome
- CO Cromo satinato/Satin chrome
- CA Cromo lucido-satinato/  
Chrome bright-satin
- ZL SuperOro lucido/SuperGold bright
- NL SuperNichel lucido/  
SuperNickel bright
- NS SuperNichel satinato/  
SuperNickel satin
- IS SuperInox satinato/  
SuperStainlessSteel satin
- RS SuperRame satinato/  
SuperCopper satin
- DS SuperBronzo satinato/  
SuperBronze satin
- US SuperAntracite satinato/  
SuperAnthracite satin

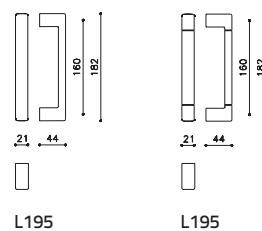



# Bios Franco Sargiani



**ottone/brass**

- CR Cromo lucido/Bright chrome
- CO Cromo satinato/Satin chrome
- NL SuperNichel lucido/  
SuperNickel bright
- IS SuperInox satinato/  
SuperStainlessSteel satin
- RS SuperRame satinato/  
SuperCopper satin
- DS SuperBronzo satinato/  
SuperBronze satin

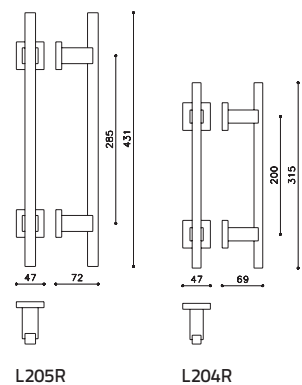

Bios Franco Sargiani



ottone/brass

- CR Cromo lucido/Bright chrome
- CO Cromo satinato/Satin chrome
- NL SuperNichel lucido/  
SuperNickel bright
- IS SuperInox satinato/  
SuperStainlessSteel satin
- RS SuperRame satinato/  
SuperCopper satin
- DS SuperBronzo satinato/  
SuperBronze satin

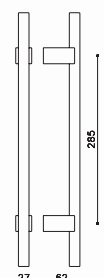

27 62 285 431



L205

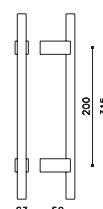

23 59 200 315



L204

Diana Studio Olivari

ottone/brass

- CR Cromo lucido/Bright chrome
- CO Cromo satinato/Satin chrome
- NL SuperNichel lucido/  
SuperNickel bright
- IS SuperInox satinato/  
SuperStainlessSteel satin
- RS SuperRame satinato/  
SuperCopper satin
- DS SuperBronzo satinato/  
SuperBronze satin
- US SuperAntracite satinato/  
SuperAnthracite satin

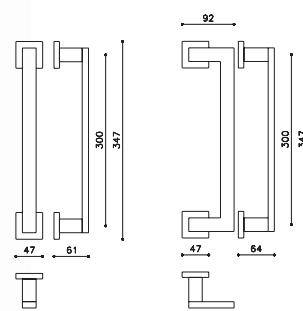

L206R

L207R

Diana Studio Olivari

ottone/brass

- CR Cromo lucido/Bright chrome
- CO Cromo satinato/Satin chrome
- NL SuperNichel lucido/  
SuperNickel bright
- IS SuperInox satinato/  
SuperStainlessSteel satin
- RS SuperRame satinato/  
SuperCopper satin
- DS SuperBronzo satinato/  
SuperBronze satin
- US SuperAntracite satinato/  
SuperAnthracite satin

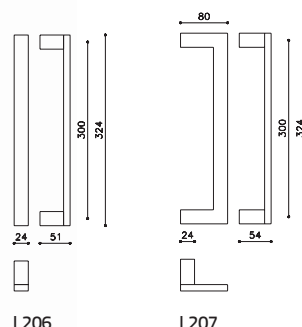

L206

L207

# Link Pietro Lissoni



**ottone/brass**

- CR** Cromo lucido/Bright chrome
- CO** Cromo satinato/Satin chrome
- NL** SuperNichel lucido/  
SuperNickel bright
- IS** SuperInox satinato/  
SuperStainlessSteel satin
- RS** SuperRame satinato/  
SuperCopper satin
- DS** SuperBronzo satinato/  
SuperBronze satin
- US** SuperAntracite satinato/  
SuperAnthracite satin

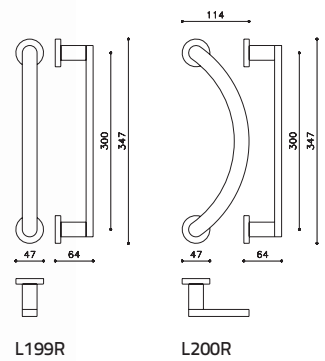



Link Pietro Lissoni



**ottone/brass**

- CR** Cromo lucido/Bright chrome
- CO** Cromo satinato/Satin chrome
- NL** SuperNichel lucido/  
SuperNickel bright
- IS** SuperInox satinato/  
SuperStainlessSteel satin
- RS** SuperRame satinato/  
SuperCopper satin
- DS** SuperBronzo satinato/  
SuperBronze satin
- US** SuperAntracite satinato/  
SuperAnthracite satin

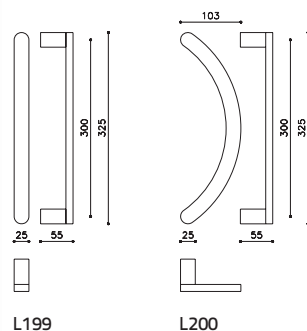

Stilo Enzo Mari



ottone/brass

- CR Cromo lucido/Bright chrome
- CO Cromo satinato/Satin chrome
- NL SuperNichel lucido/  
SuperNickel bright
- IS SuperInox satinato/  
SuperStainlessSteel satin
- RS SuperRame satinato/  
SuperCopper satin
- DS SuperBronzo satinato/  
SuperBronze satin

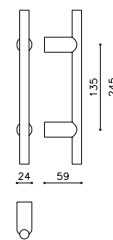

L189

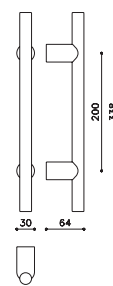

L190M

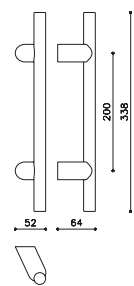

L191M

Stilo Enzo Mari



ottone/brass

CR Cromo lucido/Bright chrome

CO Cromo satinato/Satin chrome

IS SuperInox satinato/  
SuperStainlessSteel satin

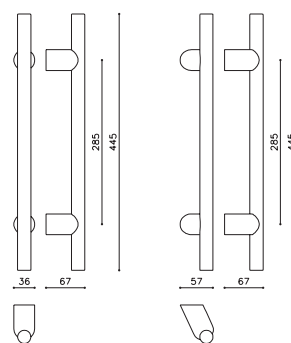

L190L

L191L

# Alexandra F.A. Porsche



ottone/brass

- CR Cromo lucido/Bright chrome
- CO Cromo satinato/Satin chrome
- IS SuperInox satinato/  
SuperStainlessSteel satin

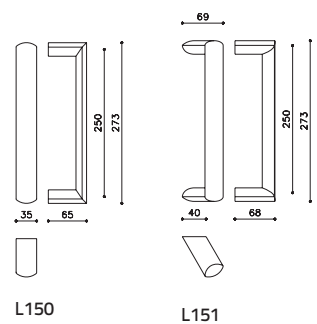

Aster Studio Olivari

ottone/brass

CA Cromo lucido-satinato/  
Chrome bright-satin

ZT SuperOro lucido-satinato/  
SuperGold bright-satin

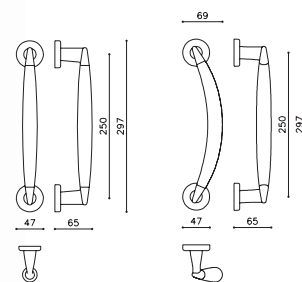

L174R

L175R



# Edison

Mazza, Gramigna

**ottone/brass**

**CR** cromato /chrome

**CO** Cromo satinato/Satin chrome

**ZL** SuperOro lucido/SuperGold bright

**IS** SuperInox satinato/  
SuperStainlessSteel satin

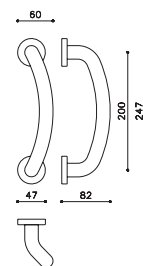

L147R

# Bond Andrea Branzi

ottone/brass

CO Cromo satinato/Satin chrome

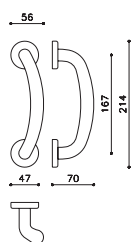

L163R

# Icaro Paolo Portoghesi

ottone/brass

ZL SuperOro lucido/SuperGold bright

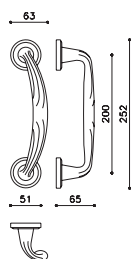

L168A



# maniglioni alzanti

pull-up handles

# Planet Q Studio Olivari



**ottone/brass**

- CR Cromo lucido/Bright chrome
- CO Cromo satinato/Satin chrome
- ZL SuperOro lucido/SuperGold bright
- TS SuperOro satinato/SuperGold satin
- NL SuperNichel lucido/  
SuperNickel bright
- NS SuperNichel satinato/  
SuperNickel satin
- IS SuperInox satinato/  
SuperStainlessSteel satin
- RS SuperRame satinato/  
SuperCopper satin
- DS SuperBronzo satinato/  
SuperBronze satin
- US SuperAntracite satinato/  
SuperAnthracite satin

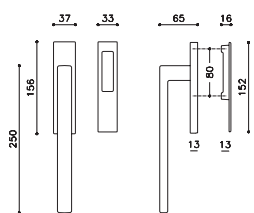

L121

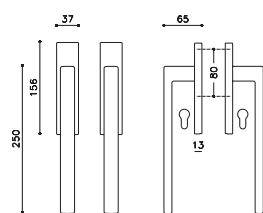

L122

# Planet Q corto Studio Olivari



**ottone/brass**

- CR Cromo lucido/Bright chrome
- CO Cromo satinato/Satin chrome
- ZL SuperOro lucido/SuperGold bright
- NS SuperNichel satinato/  
SuperNickel satin
- IS superinox satinat/  
SuperStainlessSteel satin
- US SuperAntracite satinato/  
SuperAnthracite satin

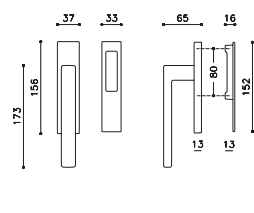

L123

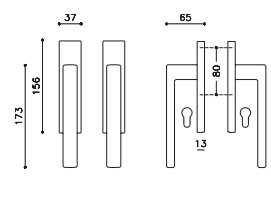

L124



# Lotus Q Javier Lopez



**ottone/brass**

- CR Cromo lucido/Bright chrome
- CO Cromo satinato/Satin chrome
- ZL SuperOro lucido/SuperGold bright
- NL SuperNichel lucido/  
SuperNickel bright
- NS SuperNichel satinato/  
SuperNickel satin
- IS SuperInox satinato/  
SuperStainlessSteel satin
- RS SuperRame satinato/  
SuperCopper satin
- DS SuperBronzo satinato/  
SuperBronze satin
- US SuperAntracite satinato/  
SuperAnthracite satin

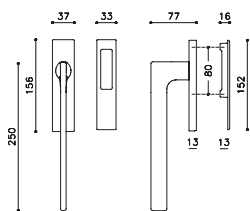

L221

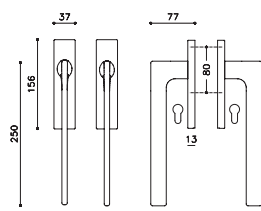

L222

# Planet Studio Olivari



**ottone/brass**

- CR Cromo lucido/Bright chrome
- CO Cromo satinato/Satin chrome
- ZL SuperOro lucido/SuperGold bright
- TS SuperOro satinato/SuperGold satin
- NL SuperNichel lucido/  
SuperNickel bright
- NS SuperNichel satinato/  
SuperNickel satin
- IS SuperInox satinato/  
SuperStainlessSteel satin
- RS SuperRame satinato/  
SuperCopper satin
- DS SuperBronzo satinato/  
SuperBronze satin
- US SuperAntracite satinato/  
SuperAnthracite satin

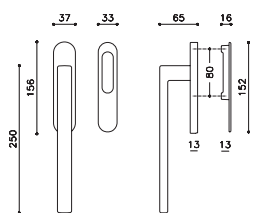

L111

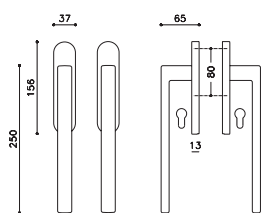

L112



**ottone/brass**

- CR Cromo lucido/Bright chrome
- CO Cromo satinato/Satin chrome
- ZL SuperOro lucido/SuperGold bright
- NS SuperNichel satinato/  
SuperNickel satin
- IS SuperInox satinato/  
SuperStainlessSteel satin
- US SuperAntracite satinato/  
SuperAnthracite satin

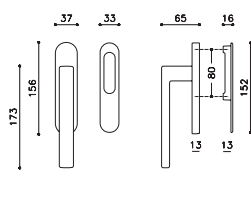

L113

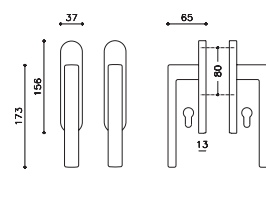

L114